

## DATA SHEET

# COLUMN AND BEAM ENCASEMENT

To achieve the required fire or acoustic rating within a building, it has become common site practice to encase both the structural columns and beams that support the general fabric of the building with XPR Gypsum Fibre FERMACELL boards.

Whilst there are a number of options available to the contractor, the speed of erecting the frame to support the board is of paramount importance.

**The contractor should be aware of the importance of this build detail:** and the need to “get it right”. It simply is unacceptable to build the support frame using a bespoke method. Failure, particularly within a fire situation, could have serious consequences.

XPR have developed **The Column and Beam Encasement Kit**, which meets all the critical criteria. It is fast to erect, and offers all the necessary support required, ensuring a safe and successful build.

Comprising of just two components for column encasement, and three for beam encasement, the kit offers a cost effective and total solution that can be fitted with confidence.

For an insulation only Beam Encasement solution log on to [www.rockwool.co.uk](http://www.rockwool.co.uk) and go to the product library section and click on the details for BeamClad Systems.

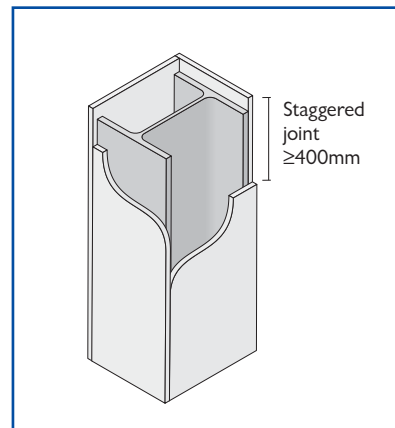

Encasement of a steel support for 4-sided exposure to fire

DATA SHEET

METHOD OF BUILD

COLUMN ENCASEMENT

Clip Profiles reference 6141 are friction fixed, at 600mm centres from floor to head, on all four corners of the column as indicated in the plan drawing detailed on the right.

Take a pre-cut to length piece of Profile Ref:5120 and snap fix over the protruding clip profile by applying hand pressure on the face of board profile 5120. Once completed on all four corners of the column the frame is ready to accept the board.

**Note:** It may be a requirement to fit ROCKWOOL FLEXI within the void of the column to enhance either the fire or acoustic rating. It is always worth checking with our **Technical Helpline (0870 803 0977)** before installation of the board to the steel frame. The boards should be screw fixed at 250mm centres at each corner from the floor to the head.

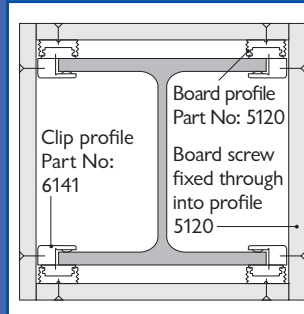

Plan details

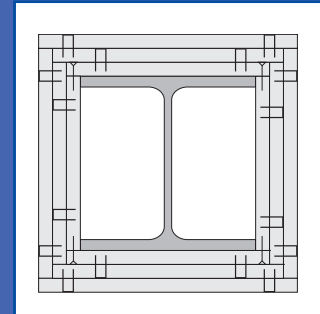

3 layer steel beam encasement for 4-sided exposure to fire

Fire resistance category – Column Encasement				
F 30-A	F 60-A	F 90-A	F 120-A	F 180-A
FERMACELL in mm				
10	2 x 10	2 x 15 1 x 12.5	4 x 15	5 x 15

Minimum lining thickness for steel girders with  $H_p/A \leq 300m^{-1}$

BEAM ENCASEMENT

A third component, Profile 5312, is required to encase a beam successfully. Clip Profiles 6141 are friction fitted at 600mm centres along the length of the underside of supporting I beam and Profile 5120 is snap fixed over the top of the clips – the identical method as that described for column encasement above.

Profile 5312 should be fitted to the concrete soffit – vertically inline with the edge of Profile 5120 as shown on the right.

The frame is now ready to accept the FERMACELL board.

**Note:** It may be a requirement to fit ROCKWOOL FLEXI within the void of the beam to enhance either the fire or acoustic rating. Contact our **Technical Helpline (0870 803 0977)** before installation of the board to the steel frame.

The board should be screw fixed at 250mm centres along the length of the beam.

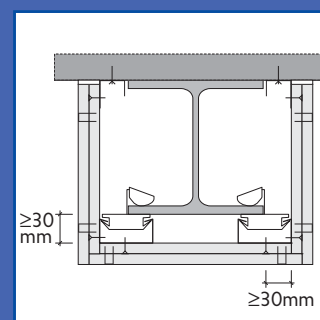
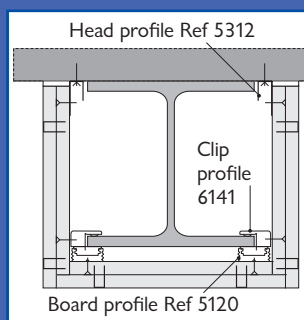

3 layer steel beam encasement for 3-sided exposure to fire

Fire resistance category – Beam Encasement			
F 30-A	F 60-A	F 90-A	F 120-A
FERMACELL in mm			
10	10 + 10	15 + 12.5	18 + 18

Minimum lining thickness for steel girders with  $H_p/A \leq 300m^{-1}$